

# OWNER'S GUIDE & INSTALLATION INSTRUCTIONS

**B744V, B744VL** TRIDUCER® Multisensor  
Retractable with Valve

**B765LH, B765LM** Transducer

U.S. Patent: 7,369,458. UK 2 414 077. U.S. Patent Pending

07/20/10

17-438-01 rev. 03

## WARNING

### The sensor must be installed with a fairing!

A fairing that is carefully cut to fit the shape of the hull provides a sealing surface around the drilled hole. If the sensor is not installed with a fairing, there may be insufficient surface area to seal the hull. Water may leak into the boat causing damage or possibly sinking.

**WARNING: B765LH, B765LM**—The B765LH/LM must be installed with a High-Performance Fairing only! It will not mate and seal with a standard fairing.

**WARNING:** A High-Performance Fairing must be installed following the Installation Instructions that come with the fairing. A High-Performance Fairing requires an anti-rotation bolt to keep the fairing from turning while the boat is underway.

**WARNING:** Always wear safety goggles and a dust mask to avoid personal injury.

**WARNING:** Immediately check for leaks when the boat is placed in the water. Do not leave the boat unchecked for more than three hours. Even a small leak may allow considerable water to accumulate.

**WARNING:** B744V, B744VL—The O-rings must be intact and well lubricated to make a watertight seal.

**WARNING:** B744V, B744VL—Always attach the safety wire to prevent the insert from backing out in the unlikely event that the cap nut and/or insert nut fails or is screwed on incorrectly.

**WARNING:** B744V, B744VL—The valve is not a watertight seal. Always install the paddlewheel insert or the blanking plug secured with the insert nut and safety wire for a watertight seal.

**WARNING:** B744V, B744VL—Do not remove the CAP nut. The valve assembly will come out. The insert/blanking plug cannot be secured without the valve assembly.

**CAUTION:** Never mount a bronze housing in a metal hull because electrolytic corrosion will occur.

Record the information found on the cable tag for future reference.

Part No. \_\_\_\_\_ Date \_\_\_\_\_ Frequency \_\_\_\_\_ kHz

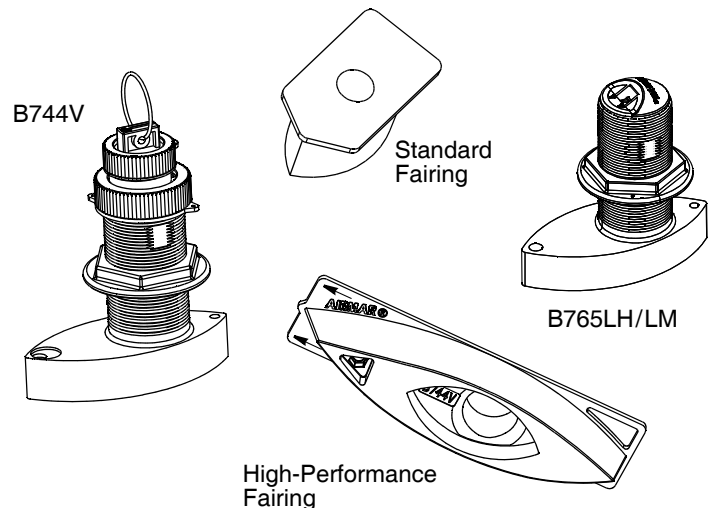

**CAUTION:** Never install a metal housing in a vessel with a positive ground system.

**CAUTION:** Never pull, carry, or hold the sensor by its cable. This may sever internal connections.

**CAUTION:** Never strike the sensor.

**CAUTION:** Never use solvents. Cleaners, fuel, sealants, paint, and other products may contain strong solvents, such as acetone, which attack many plastics, greatly reducing their strength.

**IMPORTANT:** The sensor must be installed carefully. Read the instructions completely before proceeding with the installation. These instructions supersede any other instructions in your instrument manual if they differ.

## Applications

Bronze sensor recommended for fiberglass or wood hull only.

## Identify Your Model

The model name is printed on the cable tag.

## B744V/VL: Pretest

Connect the multisensor to the instrument and spin the paddlewheel. Check for a speed reading and the approximate air temperature. If there is no reading or it is inaccurate, check the connections and repeat the test. If there is still no reading or they are inaccurate, return the product to the place of purchase.

## About High-Performance Fairings

Airmar recommends installing a High-Performance Fairing unless insufficient space demands a Standard Fairing. Airmar's High-Performance Fairings have a long streamlined shape that directs water around the sensor to minimize drag. Performance is excellent above 15 knots (see Replacement Sensor & Parts on page 6).

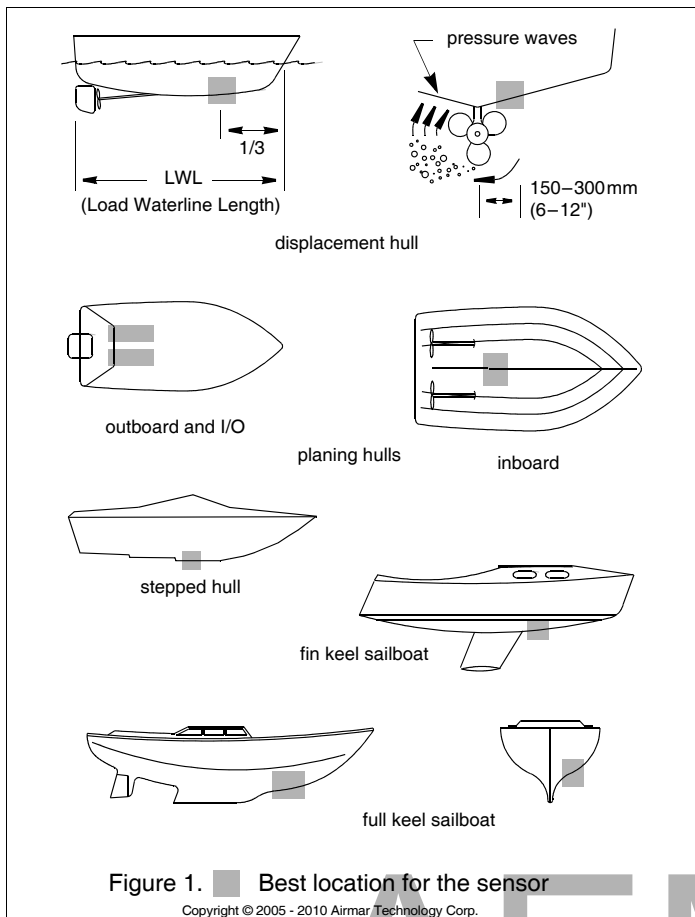

Figure 1. ■ Best location for the sensor

Copyright © 2005 - 2010 Airmar Technology Corp.

- Choose a location away from interference caused by power and radiation sources such as: the propeller(s) and shaft(s), other machinery, other echosounders, and other cables. The lower the noise level, the higher the echosounder gain setting that can be used.
- Choose a location with a minimum deadrise angle.
- Choose an accessible spot inside the vessel with adequate headroom for the height of the housing, tightening the nut(s), and installing any insert.

Model	Min. with fairing
B744V	255mm (10")
B744VL	381mm (15")

### Boat Types (see Figure 1)

- **Displacement hull powerboat**—Locate 1/3 of the way back along the LWL and 150–300mm (6–12") off the centerline. The starboard side of the hull where the propeller blades are moving downward is preferred.
- **Planing hull powerboat**—Mount well aft near the centerline and *well inboard of the first set of lifting strakes* to ensure that it is in contact with the water at high speeds. The starboard side of the hull where the propeller blades are moving downward is preferred.
- **Outboard and I/O**—Mount forward and to the side of the engine(s).
- **Inboard**—Mount well ahead of the propeller(s) and shaft(s).
- **Stepped hull**—Mount just ahead of the first step.
- **Boats capable of speeds above 25kn (29MPH)**—Review sensor location and operating results of similar boats before proceeding.
- **Fin keel sailboats**—Mount to the side of the centerline and forward of the fin keel 300–600mm (1–2').
- **Full keel sailboats**—Locate amidships and away from the keel at the point of minimum deadrise angle.

## Tools & Materials

Fairing (**MANDATORY**) (High-Performance Fairing recommended)

Safety goggles

Dust mask

Electric drill

Drill bit: 3mm or 1/8"

Hole saw: 51mm or 2"

Sandpaper

Mild household detergent or weak solvent (such as alcohol)

Angle finder or digital level

Band saw

Rasp or power tool

Marine sealant (suitable for below waterline)

Slip-joint pliers

Grommet(s) (some installations)

Cable ties

Water-based anti-fouling paint (**mandatory in salt water**)

Installation in a cored fiberglass hull (see page 4):

Hole saw for hull interior: 60mm or 2-3/8"

Cylinder, wax, tape, and casting epoxy

## Mounting Location

### Guidelines

**CAUTION:** Do not mount near water intake or discharge openings or behind strakes, fittings, or hull irregularities that will disturb the water flow.

- The water flowing under the hull must be smooth with a minimum of bubbles and turbulence (especially at high speeds).
- The sensor must be continuously immersed in water.
- The transducer beam must be unobstructed by the keel or propeller shaft(s).

### Installation: B744V/VL with Standard Fairing Only

**WARNING: B744V/VL**—These instructions are for installing a standard fairing only. If you are installing the B744V/VL with a High-Performance Fairing, you must follow the installation instructions that come with the fairing.

**WARNING: B765LH/LM must be installed with a High-Performance Fairing only!** You must follow the installation instructions that come with the fairing.

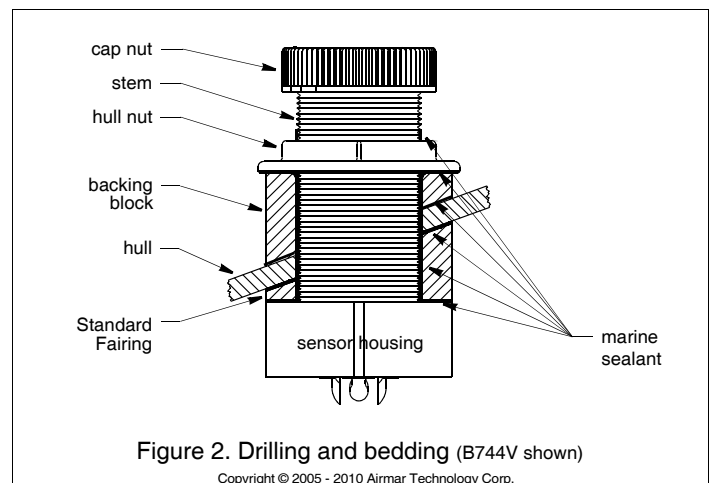

Figure 2. Drilling and bedding (B744V shown)

Copyright © 2005 - 2010 Airmar Technology Corp.

## Hole Drilling

**Cored Fiberglass Hull**—Follow separate instructions on page 4.

1. Drill a 3mm or 1/8" pilot hole perpendicular to the waterline from inside the hull (see Figure 2). If there is a rib, strut, or other hull irregularity near the selected mounting location, drill from the outside.
2. Using the 51 mm or 2" hole saw, cut a hole from outside the hull. *Be sure to hold the drill plumb, so the hole will be perpendicular to the water surface.*
3. Sand and clean the area around the hole, inside and outside, to ensure that the sealant will adhere properly to the hull. If there is any petroleum residue inside the hull, remove it with either mild household detergent or a weak solvent (alcohol) before sanding.

## Cutting the Standard Fairing

**CAUTION:** The button on the fairing points forward toward the bow. Be sure to orient the fairing on the band saw so the angle cut matches the intended side of the hull and not the mirror image.

1. Measure the deadrise angle of the hull at the selected location using an angle finder or a digital level (see Figure 3).
2. Tilt the band saw table to the measured angle and secure the cutting fence (see Figure 4).
3. Place the Standard Fairing on the table, so the cutting guide rests against the fence. The button will point *toward* you for installation on the starboard side and *away* from you for installation on the port side of the boat (see Figure 5).
4. Adjust the cutting fence so the fairing will be cut in about two equal parts. *The section that will become the fairing must be between 6–12mm (1/4–1/2") at its thinnest dimension* (see Figure 3).
5. Recheck steps 1 through 4. Then cut the fairing.
6. Shape the fairing to the hull as precisely as possible with a rasp or power tool.
7. Use the remaining section of the fairing with the cutting guide for the backing block.

## Bedding

**CAUTION:** Be sure all surfaces to be bedded are clean and dry.

1. Remove the hull nut (see Figure 2).
2. Apply a 2mm (1/16") thick layer of marine sealant over the surface of the sensor housing that will contact the fairing and up the stem. The sealant must extend 6mm (1/4") higher than the combined thickness of the fairing, hull, backing block, and hull nut. This will ensure there is marine sealant in the threads to seal the hull and hold the hull nut securely in place.
3. Apply a 2mm (1/16") thick layer of marine sealant to the surface of the:
  - Fairing that will contact the hull
  - Backing block that will contact the hull interior
  - Hull nut that will contact the backing block
4. Thread the cable through the fairing. Slide the fairing onto the stem and mate the button with the recess in the sensor's housing (see Figure 5).

## Installing the Housing

**CAUTION: B744V/VL**—Be careful to avoid cross threading the CAP nut.

1. From outside the hull, thread the cable through the mounting hole. Then push the stem of the sensor housing through the hole using a twisting motion to squeeze out excess sealant. Be sure the

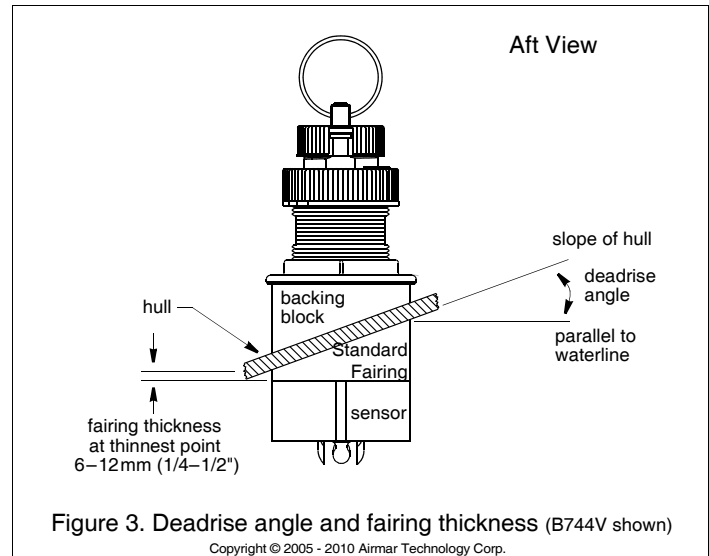

Figure 3. Deadrise angle and fairing thickness (B744V shown)

Copyright © 2005 - 2010 Airmar Technology Corp.

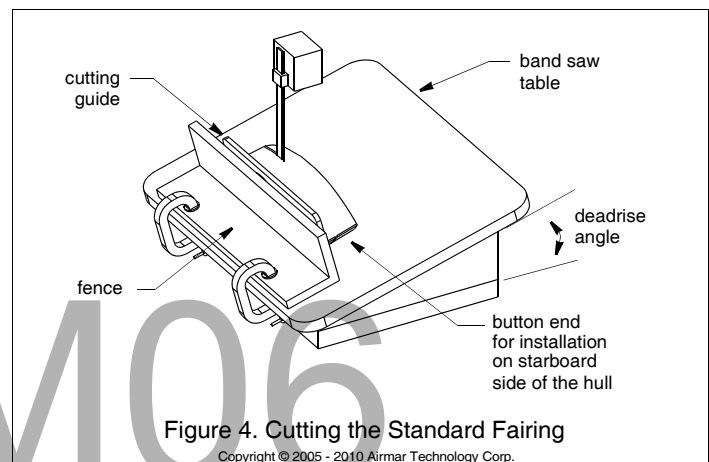

Figure 4. Cutting the Standard Fairing

Copyright © 2005 - 2010 Airmar Technology Corp.

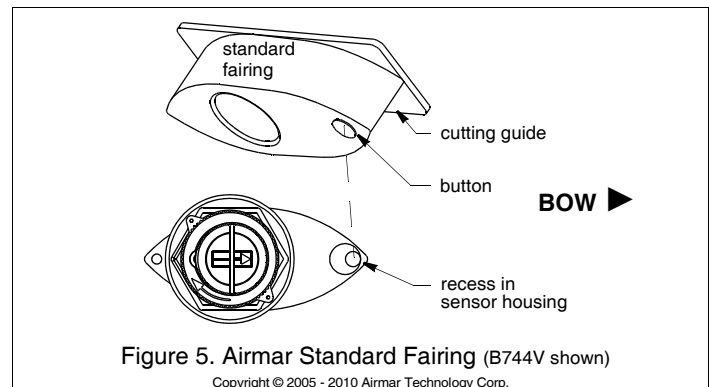
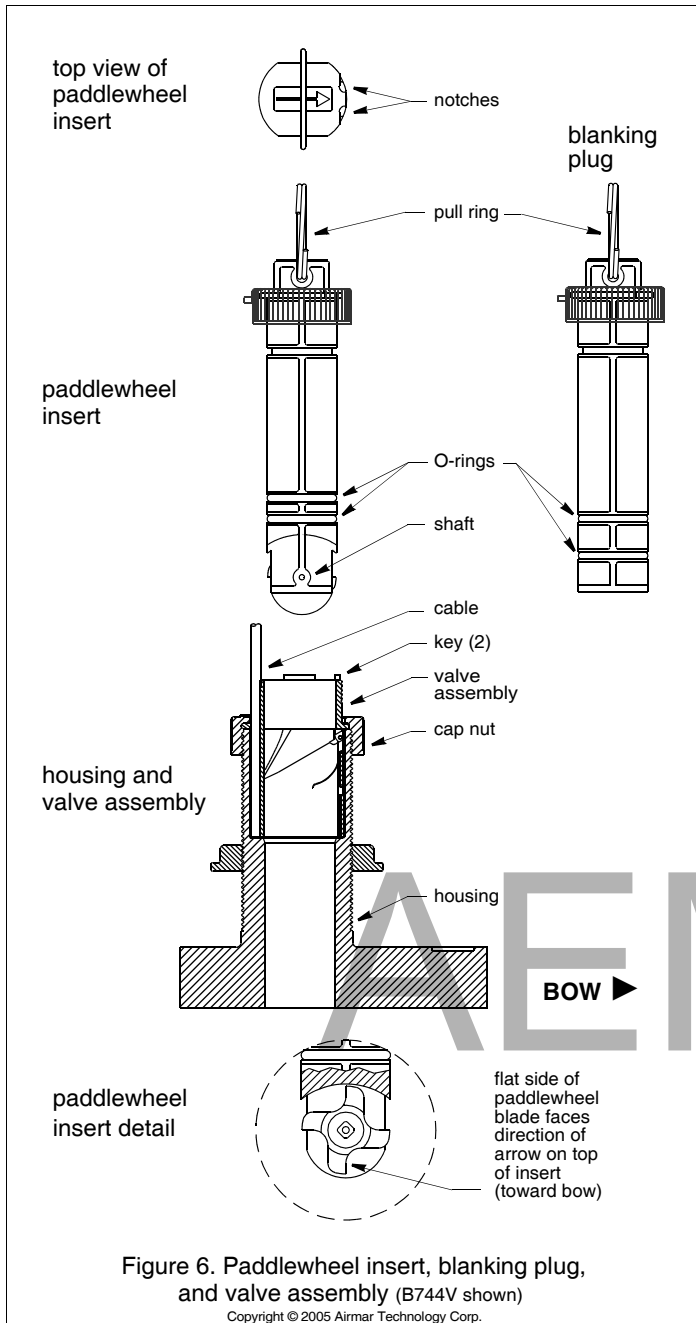

Figure 5. Airmar Standard Fairing (B744V shown)

Copyright © 2005 - 2010 Airmar Technology Corp.

button on the fairing is mated with the recess in the sensor and it is pointing forward toward the bow (see Figure 5). *Take care to align the assembly parallel to the centerline of the boat.*

2. From inside the hull, slide the backing block onto the stem and seat it firmly against the hull, being sure the pointed end faces forward toward the bow (see Figure 2). Screw the hull nut in place. Tighten it with slip-joint pliers.  
**Cored fiberglass hull**—Do not over tighten, crushing the hull.  
**Wood hull**—Allow the wood to swell before tightening.
3. **B744V/VL**—Being sure the valve assembly is seated firmly within the housing, carefully screw the CAP nut in place. **Hand-tighten** only. Do not over tighten.
4. Remove any excess sealant on the outside of the fairing and the hull to ensure smooth water flow under the sensor.



counterclockwise direction and thread it through the eye in the *insert* nut. Thread the wire through that eye a second time. Loop the wire through the pull ring and twist the wire securely to itself.

## Installation in a Cored Fiberglass Hull

The core (wood or foam) must be cut and sealed carefully. The core must be protected from water seepage, and the hull must be reinforced to prevent it from crushing under the hull nut, allowing the housing to become loose.

**CAUTION:** Completely seal the hull to prevent water seepage into the core.

1. Drill a 3mm or 1/8" pilot hole perpendicular to the waterline from inside the hull (see Figure 8). If there is a rib, strut, or other hull irregularity near the selected mounting location, drill from the outside. (If the hole is drilled in the wrong location, drill a second hole in a better location. Apply masking tape to the outside of the hull over the incorrect hole and fill it with epoxy.)

2. Using the 51 mm or 2" hole saw, cut a hole from outside the hull through the *outer* skin only. *Be sure to hold the drill plumb, so the hole will be perpendicular to the water surface.*

3. The optimal interior hole diameter is affected by the hull's thickness and deadrise angle. It must be large enough in diameter to allow the core to be completely sealed.

Using the 60mm or 2-3/8" hole saw, cut through the *inner* skin and most of the core from inside the hull keeping the drill perpendicular to the hull. The core material can be very soft. Apply only light pressure to the hole saw after cutting through the *inner* skin to avoid accidentally cutting the *outer* skin.

4. Remove the plug of core material so the *inside* of the outer skin and inner core of the hull is fully exposed. Sand and clean the inner skin, core, and the outer skin around the hole.

5. Coat a hollow or solid cylinder of the correct diameter with wax and tape it in place. Fill the gap between the cylinder and hull with casting epoxy. After the epoxy has set, remove the cylinder.

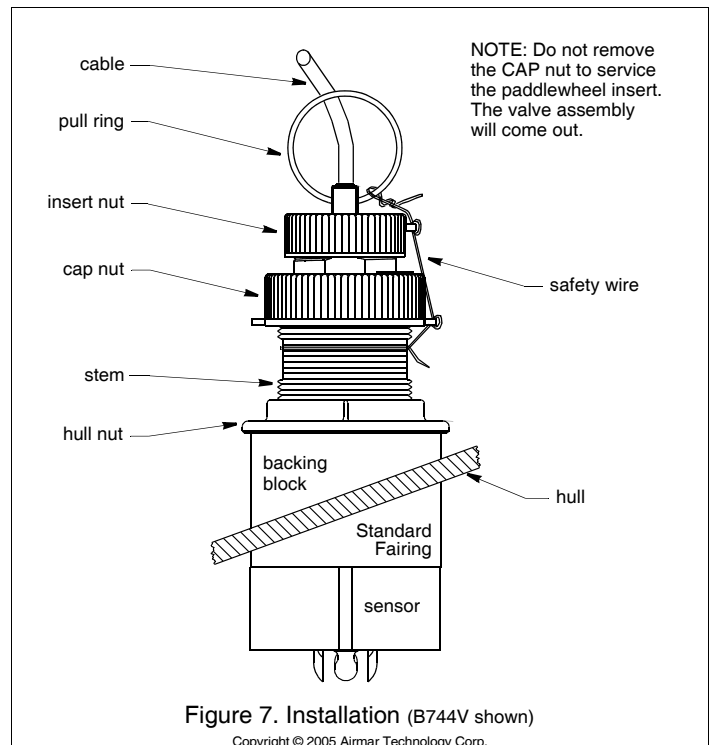

### B744V/VL: Installing the Paddlewheel Insert

1. After the sealant cures, inspect the O-rings on the paddlewheel insert (replace if necessary) and lubricate them with the silicone lubricant supplied (see Figure 6). The O-rings must be intact and well lubricated to make a watertight seal.

2. Slide the paddlewheel insert into the housing with the *arrow on the top pointing forward toward the bow*. Seat it into place using a twisting motion until the keys fit into the notches. (The insert fits one way only.) Be careful not to rotate the outer housing and disturb the sealant. Screw the insert nut in place and **hand-tighten** only. Do not over tighten.

3. Attach the safety wire to prevent the insert from backing out in the unlikely event that the cap nut and/or insert nut fails or is screwed on incorrectly. Wrap one end of the safety wire tightly around the stem of the housing and twist it together with the long end (see Figure 7). Keeping the wire taut throughout, lead the wire straight up and through one eye in the CAP nut. Thread the wire through the eye a second time. Lead the wire in a

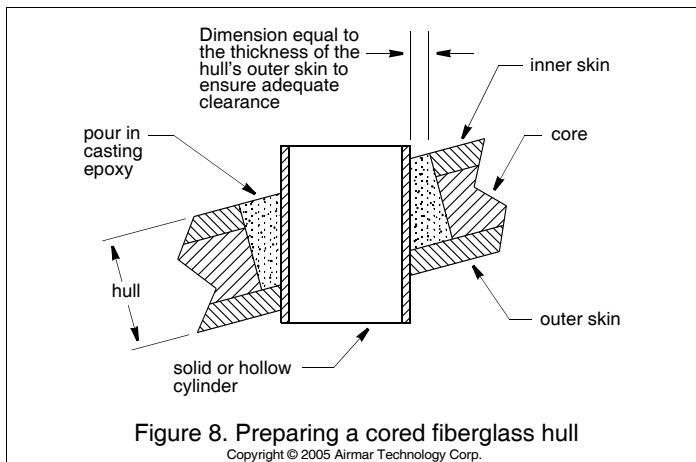

- Sand and clean the area around the hole, inside and outside, to ensure that the sealant will adhere properly to the hull. If there is any petroleum residue inside the hull, remove it with either mild household detergent or a weak solvent (alcohol) before sanding.
- Proceed with "Cutting the Standard Fairing" on page 3.

## Cable Routing & Connecting

**CAUTION:** If the sensor came with a connector, do not remove it to ease cable routing. If the cable must be cut and spliced, use Airmar's splash-proof Junction Box No. 33-035 and follow the instructions supplied. Removing the waterproof connector or cutting the cable, except when using a water-tight junction box, will void the sensor warranty.

- Route the cable to the instrument, being careful not to tear the cable jacket when passing it through the bulkhead(s) and other parts of the boat. Use grommets to prevent chafing. To reduce electrical interference, separate the sensor cable from other electrical wiring and the engine. Coil any excess cable and secure it in place using cable ties to prevent damage.
- Refer to the echosounder owner's manual to connect the sensor to the instrument.

## Check for Leaks

When the boat is placed in the water, **immediately** check around the sensor for leaks. Note that very small leaks may not be readily observed. Do not leave the boat in the water for more than 3 hours before checking it again. If there is a small leak, there may be considerable bilge water accumulation after 24 hours. If a leak is observed, repeat "Bedding" and "Installing" **immediately** (see page 3).

## Operation & Maintenance

### Anti-fouling Paint

Surfaces exposed to salt water must be coated with anti-fouling paint. Use **water-based** anti-fouling paint only. Never use ketone-based paint since ketones can attack many plastics possibly damaging the transducer. Reapply paint every 6 months or at the beginning of each boating season.

### B744V/VL: Additional Anti-fouling Paint

Paint the following surfaces (see Figure 9).

- Exposed areas of the housing including the transducer's face
- Bore of the housing up 30 mm (1-1/4")
- Outside wall of the paddlewheel insert below the lower O-ring
- Paddlewheel cavity
- Paddlewheel
- Blanking plug below the lower O-ring including the exposed end

## Cleaning the Sensor

Aquatic growth can accumulate rapidly on the sensor's surface, reducing its performance within weeks. Clean the surface with mild household detergent and a Scotch-Brite® scour pad.

**B744V/VL**—If fouling on the insert is severe, push out the paddlewheel shaft using a spare shaft or a 4-D finish nail with a flattened point. Then lightly wet sand the paddlewheel with fine grade wet/dry paper.

## B744V/VL: How the Valve Works

### WARNING: The valve is not a watertight seal!

Always install the paddlewheel insert or the blanking plug secured with the insert nut and safety wire for a watertight seal.

The multisensor incorporates a self-closing valve which minimizes the flow of water into the vessel when the paddlewheel insert is removed (see Figure 6). The curved flap valve is activated by both a spring and water pressure. Water pushes the flap valve upward to block the opening, so there is no gush of water into the boat.

## B744V/VL: Using the Blanking Plug

To protect the paddlewheel, use the blanking plug:

- When the boat will be kept in salt water for more than a week.
  - When the boat will be removed from the water.
  - When aquatic growth buildup on the paddlewheel is suspected due to inaccurate readings from the instrument.
- On the blanking plug, inspect the O-rings (replace if necessary) and lubricate them with silicone lubricant or petroleum jelly (Vaseline®) (see Figure 6). The O-rings must be intact and well lubricated to make a watertight seal.
  - Remove the paddlewheel insert from the housing by removing the safety wire from the pull ring and the *insert nut* (see Figure 7). Unscrew the *insert nut*. **Do not remove the CAP nut, as the valve assembly will come out.**
  - Grasp the pull ring and remove the paddlewheel insert with a slow pulling motion.
 

**NOTE:** In the unlikely event that the paddlewheel insert cannot be removed, see "Servicing the Valve Assembly" on page 6.
  - Slide the blanking plug into the housing. Seat it into place with a pushing twisting motion until the keys fit into the notches (see Figure 6). Screw the insert nut in place and **hand-tighten** only. Do not over tighten.
  - Reattach the safety wire (see Figure 7).

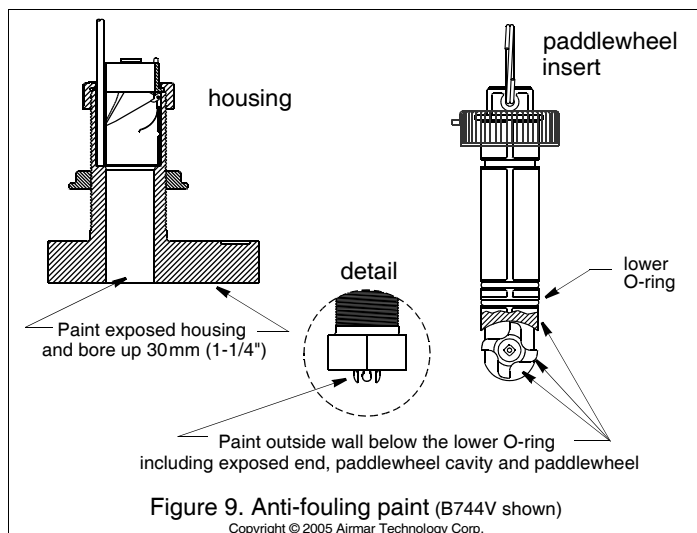

### B744V/VL: Servicing the Valve Assembly

**WARNING:** The insert/blanking plug cannot be secured without the valve assembly. Do not leave the boat in the water unattended without the valve assembly in place. This is not a watertight or secure seal!

**CAUTION:** Be careful to avoid cross threading the CAP nut.

Should the valve fail, it will need to be removed for servicing. Follow the steps below. If a new valve assembly is required and not immediately available, **the valve sleeve must be reinstalled in the multisensor housing for a watertight seal.** Remove the flap valve, spring pin, and spring from the sleeve (see Figure 10). Then reinstall the sleeve in the housing.

1. On the blanking plug, inspect the O-rings (replace if necessary) and lubricate them with silicone lubricant or petroleum jelly (Vaseline®) (see Figure 6). The O-rings must be intact and well lubricated to make a watertight seal.
2. Remove the safety wire and unscrew the CAP nut (see Figure 7). With the blanking plug ready in one hand, **remove the paddlewheel insert and valve assembly as one unit** by grasping the pull ring and pulling upward. Rapidly replace the valve assembly with the blanking plug to minimize the flow of water into the boat. **Temporarily** secure it with the safety wire. **Do not leave the boat in the water unattended.** This is not a watertight or secure seal!
3. Separate the paddlewheel insert from the valve assembly by unscrewing the insert nut (see Figure 6). Grasp the pull ring and pull slowly upward.
4. Clean, repair, or replace the valve assembly so the flap valve moves freely and seats against the sleeve (see Figure 10).
5. To reinstall the valve assembly, inspect the O-rings on the paddle-wheel insert (replace if necessary) and lubricate them with silicone lubricant or petroleum jelly (Vaseline®) (see Figure 6). The O-rings must be intact and well lubricated to make a watertight seal.
6. Slide the paddlewheel insert into the valve assembly. Seat it in place with a twisting motion until the keys fit into the notches. Secure the paddlewheel insert with the **insert nut. Hand-tighten** only. Do not over tighten.
7. Remove the safety wire from the multisensor. With the combined valve assembly and paddlewheel insert ready in one hand, remove the blanking plug. Slide the assembly into the multisensor housing **with the arrow on the top pointing forward toward the bow.** Be sure the cable fits into the cable channel and the notch in the sleeve fits into the key in the housing (see Figure 10). (A pushing twisting motion will locate the key.) Screw the CAP nut in place, being careful to avoid cross-threading. **Hand-tighten** only. Do not over tighten.
8. Reattach the safety wire (see Figure 7).

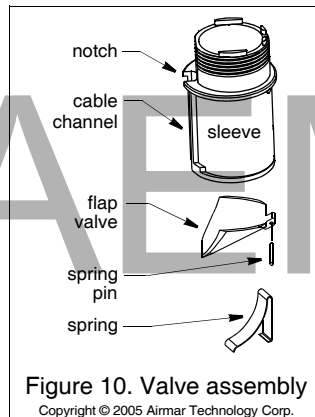

Figure 10. Valve assembly  
Copyright © 2005 Airmar Technology Corp.

### B744V/VL: Servicing the Paddlewheel Insert

The water lubricated paddlewheel bearings have a life of up to 5 years on low-speed boats [less than 10kn (11MPH)] and 1 year on high-speed vessels. Paddlewheels can fracture and shafts can bend due to impact with water borne objects and mishandling in boat yards. O-rings must be free of abrasions and cuts to ensure a watertight seal. Order a replacement Paddlewheel Kit No. 33-113.

1. Using the new paddlewheel shaft, push out the old shaft about 6mm (1/4"). With pliers, remove the old shaft (see Figure 6).
2. Place the new paddlewheel in the cavity with the flat side of the blade facing the same direction as the arrow on the top of the insert.
3. Tap in the new shaft into place until the ends are flush with the sides of the insert.
4. Install two O-rings in the *lower* groves near the paddlewheel. Do not place them near the pull ring.
5. The remaining two O-rings are placed in a similar position on the blanking plug.
6. To reinstall the paddlewheel insert, see "Installing the Paddlewheel Insert" on page 4.

### B744V/VL: Winterizing

After the boat has been hauled for winter storage, remove the blanking plug to let the water drain away before reinserting it. This will prevent any water from freezing around the blanking plug and possibly cracking it.

### Replacement Sensor & Parts

The information needed to order a replacement Airmar sensor is printed on the cable tag. **Do not remove this tag.** When ordering, specify the part number, date, and frequency in kHz. For convenient reference, record this information at the top of page one.

Lost, broken, or worn parts should be replaced immediately.

Model	Standard Fairing	High-Performance Fairing	Hull Nut	Cap Nut	Blanking Plug	Insert
B744V	04-469-01	33-476-01	02-030	04-234-1	33-551-01	33-590-01
B744VL	04-469-01	33-476-01	02-030	04-234-1	33-551-03	33-590-02
B765LH B765LM	NA	33-476-01	02-030	NA	NA	NA

Paddlewheel Kit 33-113  
Paddlewheel & Valve Kit 33-535-01

Obtain parts from your instrument manufacturer or marine dealer.

Gemeco (USA) Tel: 803-693-0777  
Fax: 803-693-0477  
email: sales@gemeco.com

Airmar EMEA (Europe, Middle East, Africa) Tel: +33.(0)2.23.52.06.48  
Fax: +33.(0)2.23.52.06.49  
email: sales@airmar-emea.com